

# TeleVue®-85 Operating Guide

600mm f/7  
2-ELEMENT APO REFRACTOR



Thank you for purchasing the **Tele Vue-85**. We hope it brings great enjoyment to your observing experience. The wonderfully versatile hand-built 3-1/3" aperture telescope features a diffraction limited, 600mm focal length, f/7 APO doublet objective which delivers razor sharp images sure to please you for years to come and wherever your observing interests lead you.



**WARNING:** NEVER try to look at the sun or point the telescope toward or near the sun without professional solar observing equipment rigidly secured in front of the objective lens. When observing the sun with the proper filters, use only the Tele Vue "Sol-Searcher" (SSF-1006) for finding the Sun. Remove any other finding devices such as Starbeam from the telescope. Instant and permanent eye damage may result from viewing the sun directly, even during a solar eclipse, or when viewing through thin clouds, or when the sun is near the horizon.

**Standard features** of the optical tube assembly (O.T.A.) include: sliding dew shield, screw-on cover, 2" rack and pinion focuser, and custom padded carrying bag.

## Accessories

The **Tele Vue-85** Accessory Package includes a 2" Everbrite diagonal, 2" to 1 1/4" adapter, Ring Mount, and Delite eyepiece.

**Mounting** - The Tele Vue Ring Mount (available separately or in the package) permits mounting to the Tele Vue Gibraltar, Panoramic, and Tele-Pod mounts, or heavy duty camera tripods. You will receive the two 1/4-20 studs, wing knobs, Allen wrench and complete mount assembly instructions with the mount. Tele Vue also has adapter plates to allow attachment on specific equatorial mounts (consult your Tele Vue dealer).

**Finders** - For night use, we recommend the Starbeam reflex sight (SRT-2010) to complement the wide field of the telescope. The Starbeam attaches to the Ring Mount on the side opposite the bat-handle. (To mount on the opposite side: simply remove the scope from the Ring Mount and switch the bat-handle and socket head screw locations.) Starbeam can be left in place when the scope is stored in its case.

Use the Qwik-Point (part # QBT-1006) for daytime spotting. Its beam is bright enough for use in even bright sunlight. However it is not recommended for nighttime use.

**Terrestrial Viewing Considerations** - Indeed, the Cornell Ornithology Lab comparison reported the Tele Vue-85 as having the finest optics for birding.

The Tele Vue 55mm Plössl or 41mm Panoptic in a 2" diagonal will provide a 4.4° true field. This can serve as a finder, for rich field viewing or for terrestrial use. (Image is upright, but left-right reversed using diagonal mirrors.)

Tele Vue developed the 1¼" 60° Everbrite Diagonal (part# DPC-6012) specifically for terrestrial observers who appreciate the highest levels of image performance. The 60° angle is far more comfortable for terrestrial observing than the standard 90°, and the 99% reflective Everbrite dielectric coating gives the truest color rendition of any mirror or prism, and is sharpest at the highest powers.

For 1¼" diagonals and prisms, the 32mm Plössl or 24mm Panoptic offer the maximum field. 2.6° at 19x and 25x respectively.

If you use the telescope in a harsh environment such as at a beach where sand, mud and salt spray are present, or for birding, you may wish to use a 95mm clear filter for protection, while using the telescope. It is available from camera dealers, and simply screws onto the lens cell in place of the cover. These filters are generally not used for astronomy as they can degrade optical quality.

## **Getting Acquainted with Your New Tele Vue-85**

Note: O.T.A. purchasers must supply eyepieces, eyepiece adapter, diagonal, and ring mount in order for the telescope to function. **TV-85** Accessory Package includes these items.

### **1.1 Optical Tube Assembly**

The OTA consists of the objective cell, tube and focuser. The front cell houses the carefully aligned objective. Never attempt to loosen the 3 alignment screws in the front lens cell. The tube is aluminum and powder coated, requiring no special care. The rack and pinion focuser is driven by high leverage 1:1 knobs on both the left and right sides, and a 10:1 reduction knob only on the right side. The two tension screws on the top of the focuser body can be adjusted to add resistance when using heavy eyepieces. These tension screws tighten against a brass clamp ring, which then cinches down on the Teflon sleeve in which the draw tube slides. For photography it is not necessary to tighten beyond the need to keep a camera stationary. Even when sufficiently tight, the focuser knobs can still drive the draw tube. The two lock screws in the end of the draw tube also tighten against a brass clamp ring for extra holding power on the diagonal or other accessories.

### **1.2 Ring Mount**

The Ring Mount (available separately or in the package) permits easy telescope balancing. Simply unlock the "bat handle," reposition the telescope by sliding it fore or aft, and re-lock. Slots with 10-32 holes are available for mounting accessories.

### **1.3 Eyepieces**

Tele Vue eyepieces offer a range of magnifications from 11x to 200x, with the **Tele Vue-85**. We recommend choosing low and medium power eyepieces in ratios of field stop diameters. For example, factors of 1.4 or 2.0. When choosing higher power eyepieces, use ratios of magnification. (see reference chart in the "Choosing Your Eyepieces" article.) The **TV-85** Accessory Package includes an 18.2 Delite that offers a 1.8° true field at 33x magnification with 20mm of eye relief.

### **1.4 Photography**

For prime focus photography at 600mm f/7 using a DSLR, use camera adapter (part# ACM-2000). For flat field astrophotography at 480mm f/5.6, use the Tele Vue 0.8x reducer/flattener, (part# TRF-2008). Tele Vue Powermates with optional T-ring adapters provide a variety of options for extending focal length. To reach focus with the Powermates requires our 3.5" extension tube. Afocal photography using your cell phone camera is accomplished with FoneMate™ (part# SFA-001). For Piggyback DSLR photography, attach the Piggy-Cam platform, (part# PGC-1001) to the Ring Mount.

The dual speed focuser with its 10:1 focus reduction provides extraordinarily fine focus adjustment for critical focusing. The Focusmate Driver (part# FDF-2004) adds hands free motorized focusing.

OTA shown with optional TV-85 Accessory Package (TVP-3373\*)

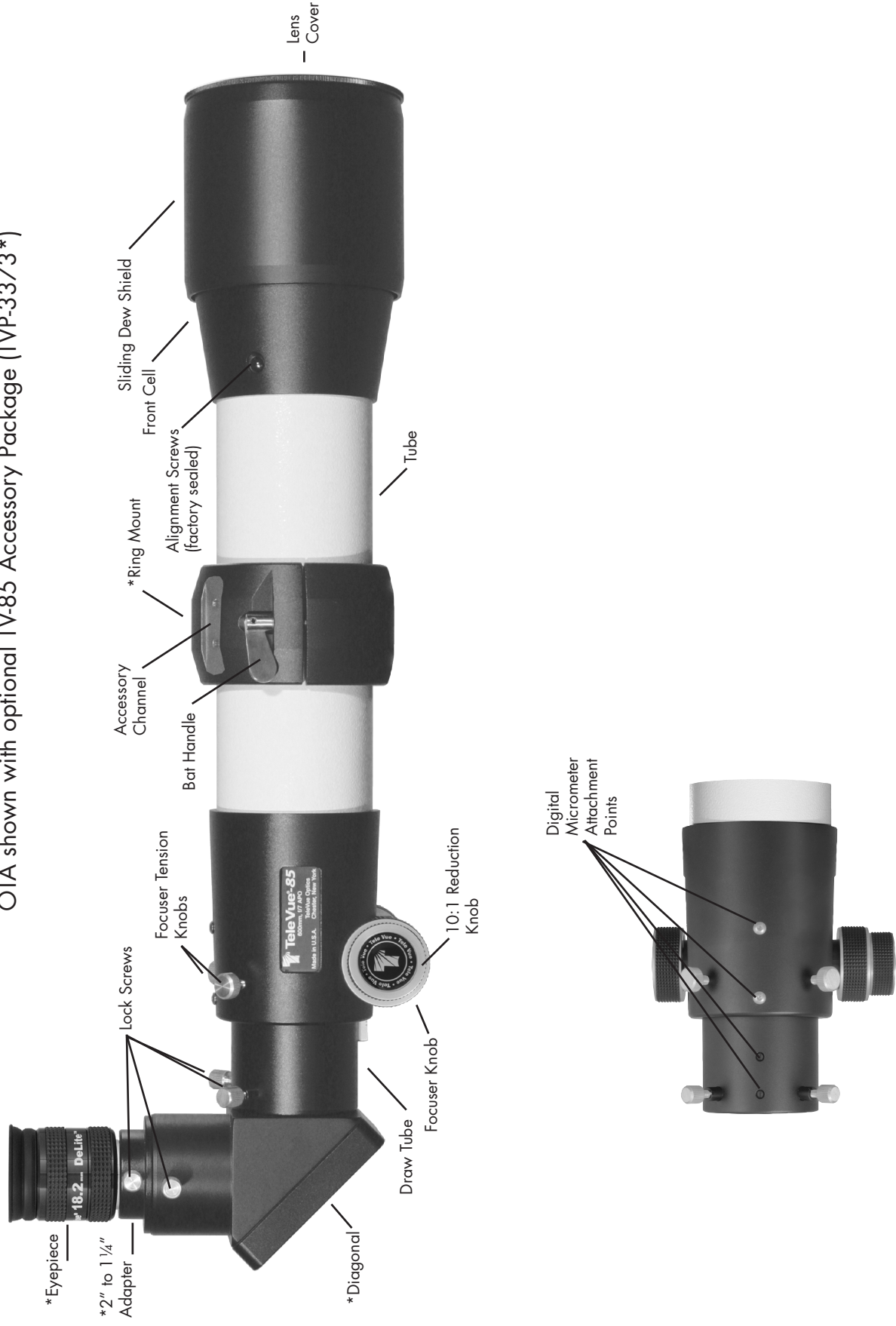

Tele Vue recommends choosing low and medium power eyepieces in ratios of field stop diameters. For example, factors of 1.4 or 2.0. When choosing higher power eyepieces, use ratios of magnification.

Tele Vue-85											
Focal Length (mm)	Type	Product Code	Apparent Field (deg)	Field Stop Dia. (mm)	Eye Relief (mm)	Weight (lb.)	Mag.	True Field (deg)	Exit Pupil (mm)	# of Elem.	Dioptrx Ready
<b>2" Eyepieces for Wide True Fields</b>											
55	Plössl	EPL-55.0†	50	46.0	38	1.1	10.9	4.39	7.8	4	Y
41	Panoptic	EPO-41.0	68	46.0	27	2.1	14.6	4.39	5.8	6	Y
31	Nagler 5	EN5-31.0	82	42.0	19	2.2	19.4	4.01	4.4	6	Y
35	Panoptic	EPO-35.0	68	38.7	24	1.6	17.1	3.70	5.0	6	Y
21	Ethos	ETH-21.0	100	36.2	15	2.3	28.6	3.46	3.0	-	Y
22	Nagler 4	EN4-22.0	82	31.1	19	1.5	27.3	2.97	3.1	7	Y
27	Panoptic	EPO-27.0	68	30.5	19	1.0	22.2	2.91	3.8	6	Y
17	Ethos	ETH-17.0	100	29.6	15	1.6	35.3	2.83	2.4	-	Y
<b>1 1/4" Eyepieces for Wide True Fields</b>											
40	Plössl	EPL-40.0	43	27.0	28	0.4	15.0	2.58	5.7	4	Y
32	Plössl	EPL-32.0	50	27.0	22	0.4	18.8	2.58	4.5	4	Y
24	Panoptic	EPO-24.0	68	27.0	15	0.5	25.0	2.58	3.4	6	Y*
13	Ethos	ETH-13.0	100	22.3	15	1.3	46.2	2.13	1.8	-	Y
16	Nagler 5	EN5-16.0	82	22.1	10	0.4	37.5	2.11	2.3	6	N
19	Panoptic	EPO-19.0	68	21.3	13	0.4	31.6	2.03	2.7	6	Y*
25	Plössl	EAP-25.0	50	21.2	17	0.3	24.0	2.02	3.5	4	N
17.3	Delos	EDL-17.3	72	21.2	20	0.9	34.7	2.02	2.5	-	Y
18.2	DeLite	EDE-18.2	62	19.1	20	0.5	33.0	1.82	2.6	-	Y
10	Ethos	ETH-10.0	100	17.7	15	1.1	60.0	1.69	1.4	-	Y
13	Nagler 6	EN6-13.0	82	17.6	12	0.4	46.2	1.68	1.8	7	Y*
14	Delos	EDL-14.0	72	17.3	20	0.9	42.9	1.65	2.0	-	Y
20	Plössl	EAP-20.0	50	17.1	14	0.2	30.0	1.63	2.8	4	N
11	Apollo (disc)	EAL-11.0	85	16.2	18	1.4	54.5	1.55	1.6	-	Y
15	DeLite	EDE-15.0	62	16.0	20	0.5	40.0	1.53	2.1	-	Y
<b>1 1/4" Eyepieces for Medium Powers</b>											
12	Delos	EDL-12.0	72	15.0	20	0.9	50.0	1.43	1.7	-	Y
13	DeLite	EDE-13.0	62	13.8	20	0.5	46.2	1.32	1.8	-	Y
10	Delos	EDL-10.0	72	12.7	20	0.9	60.0	1.21	1.4	-	Y
15	Plössl	EAP-15.0	50	12.6	10	0.2	40.0	1.20	2.1	4	N
9	Nagler 6	EN6-09.0	82	12.4	12	0.4	66.7	1.18	1.3	7	Y*
11	DeLite	EDE-11.0	62	11.7	20	0.4	54.5	1.12	1.6	-	Y
9	DeLite	EDE-09.0	62	9.6	20	0.5	66.7	0.92	1.3	-	Y
11	Plössl	EAP-11.0	50	9.1	8	0.1	54.5	0.87	1.6	4	N
<b>1 1/4" Eyepieces for Higher Powers</b>											
8	Ethos	ETH-08.0	100	13.9	15	1.0	75.0	1.33	1.1	-	Y
6	Ethos	ETH-06.0	100	10.4	15	1.0	100.0	0.99	0.9	-	Y
8	Delos	EDL-08.0	72	9.9	20	1.0	75.0	0.95	1.1	-	Y
7	Nagler 6	EN6-07.0	82	9.7	12	0.5	85.7	0.93	1.0	7	Y*
4.7	Ethos SX	ETH-04.7	110	8.9	15	1.3	127.7	0.85	0.7	-	Y
6	Delos	EDL-06.0	72	7.6	20	1.0	100.0	0.73	0.9	-	Y
7	DeLite	EDE-07.0	62	7.5	20	0.5	85.7	0.72	1.0	-	Y
3.7	Ethos SX	ETH-03.7	110	7.0	15	1.1	162.2	0.67	0.5	-	Y
5	Nagler 6	EN6-05.0	82	7.0	12	0.5	120.0	0.67	0.7	7	Y*
8	Plössl	EAP-08.0	50	6.5	6	0.1	75.0	0.62	1.1	4	N
4.5	Delos	EDL-04.5	72	5.6	20	1.1	133.3	0.53	0.6	-	Y
5	DeLite	EDE-05.0	62	5.3	20	0.5	120.0	0.51	0.7	-	Y
3.5	Nagler 6	EN6-03.5	82	4.8	12	0.5	171.4	0.46	0.5	7	Y*
3.5	Delos	EDL-03.5	72	4.4	20	1.1	171.4	0.42	0.5	-	Y
4	DeLite	EDE-04.0	62	4.3	20	0.5	150.0	0.41	0.6	-	Y
3	DeLite	EDE-03.0	62	3.2	20	0.5	200.0	0.31	0.4	-	Y
<b>1 1/4" Zoom Eyepieces for Medium and Higher Powers</b>											
6-3	Nagler Zoom	ENZ0306	50	5.1-2.6	10	0.3	100.0-200.0	0.49-0.25	0.9-0.4	5	N

NOTE: True Field in degrees = (Field Stop dia./Telescope Focal Length) X 57.3°

\*Indicates additional Dioptrx Adapter required

## **1.5 Caring for the Tele Vue-85**

**Tele Vue-85** requires no special care. Treat it as you would any fine camera lens. Use the lens cap when the telescope is being stored or not in use. The captive dew shield provides protection from glare, helps protect the lens from dust or spray blown in by the wind and minimizes dew formation on the lens.

If dew forms on the lens during cold weather, it is best to use an electric hair dryer (on the lowest setting) to gently warm it away. A few specks of dust will have no effect on the quality of the image, and may be gently blown off with a squeeze bulb. Do not use compressed air cans to blow dust off any optical surfaces.

Fingerprints, however should be cleaned off. Though the anti-reflection coatings are durable, they are easily scratched. The simplest cleaning method is to moisten a very soft, lint-free tissue, cloth, "Q-Tip" or surgical cotton with a lens or glass cleaner and gently whisk away the stain. Do not apply any solutions directly to the glass surfaces. After every cleaning stroke, use a fresh applicator. The fewer strokes the better! Any residual "film" will not affect visual performance.

Collimation of your **Tele Vue-85** has been locked at the factory. With reasonable care it will remain aligned. However, rough handling can cause misalignment. **WARNING:** Do not loosen the button head screws in the front lens cell as this will cause misalignment. If necessary, contact Tele Vue for re-collimation.

Our 90° and 60° star diagonals employ a first-surface mirror. Like all first-surface mirrors, they should be cleaned only when absolutely necessary. First blow loose dust away with a squeeze bulb. **CAUTION:** Do not clean mirror with water or water based cleaners such as Windex or any other commercial lens cleaners; this is not a lens. All contain too much water and will leave a residue. Moisten a "Q-Tip" with methanol or Isopropyl alcohol, reagent grade. Clean gently using only the weight of the cotton swab. Use very light pressure and never rub. Slight residual stains or dust spots will have no visible effects in observing.

The tube and other parts are powder-coated for durability and can be polished with any non-abrasive car wax. Black anodized surfaces can be cleaned with Windex.

If you have any questions about the care, operation or performance of your **Tele Vue-85**, please call Tele Vue at (845) 469-4551 from 9:30 am to 5:00 pm EST.

## **1.6 Warranty**

Tele Vue telescopes are warranted to be free of manufacturing or workmanship defects for 5 (five) years from the date of purchase, to the original owner. Please return the warranty card as validation of your ownership and for easy identification. If your Tele Vue telescope requires warranty service, please call Tele Vue to discuss the problem, upon which you will receive a return authorization. **NO RETURNS ARE ACCEPTED WITHOUT PRIOR AUTHORIZATION.** A copy of your sales receipt maybe requested if you have not submitted your warranty registration material.

The warranty does NOT include: collimation, defects caused by mishandling, defects of subjective nature, or coverage for any telescope purchased through an unauthorized Tele Vue dealer. However, for claims of telescopes arriving out of collimation you must contact Tele Vue Optics within 30 days from date of delivery, verifiable by sales receipt.

Warranty work will be performed at Tele Vue's discretion and may only be performed by Tele Vue Optics or Tele Vue authorized agent. The telescope must be shipped in its case with proper inner and outer packaging. Shipping and insurance charges are the purchaser's responsibility.

## 1.7 Specifications

Type	2-element APO refractor, Fully Multi-Coated
Clear Aperture	3.35 inches (85mm)
Aperture Gain	147, compared to a 7mm exit pupil
Focal Length	600mm
Focal Ratio	f/7
Resolution (visual)	1.4 arc-sec. (Dawes Limit for a 3.35-inch aperture)
Resolution (photographic)	200 line pairs per mm
Magnification	11x to 200x using Tele Vue eyepieces
Field, Visual	4.4° at 11x
Focuser	2-inch, rack and pinion type with 10:1 reduction
Tube	Powder-coated aluminum
Length	19.0-inches (O.T.A. only) 21.9-inches with 2" star diagonal
Weight	5.95 lbs. (tube assembly with no caps) 8.20 lbs. (tube assembly in case with caps)
Accessories	custom fitted soft case, screw-on lens cover, sliding dew (glare) shield

Specifications subject to change without notice.

## 1.8 Recommended Accessories

Finder Starbeam or 55mm Plössl for 11x, 4.4° field

### Recommended TV-*85* Accessory Package (TVP-3373) includes:

Eyepiece	18.2mm DeLite for 33x, 1.8° field
Diagonal	2-inch Everbite 99% broadband mirror type, with 1 1/4" adapter
Mounting	Adjustable 3" Ring Mount with 1/4-20 tapped holes for standard photographic tripods or optional Tele Vue mountings

## 1.9 Photo-visual Configurations

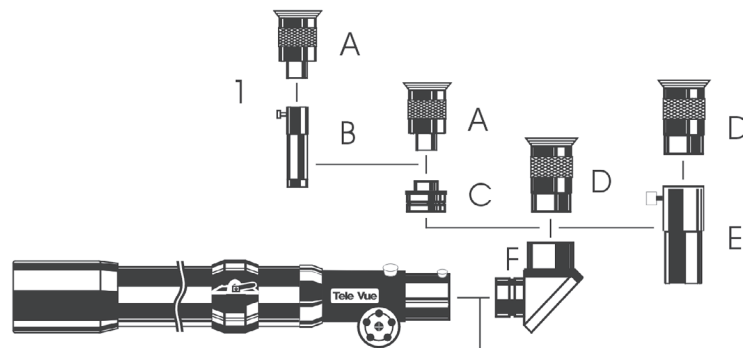

1. Astronomical Viewing
2. Terrestrial Viewing
3. Prime Focus Photography
4. Prime Focus Photography with 0.8x Reducer/Flattener
5. Prime Focus Photography with Powermates
6. Afocal Photography
7. In-line Afocal Photography

- A. 1 1/4" Eyepiece
- B. 1 1/4" Barlow or Powermate
- C. 2" to 1 1/4" Reducing Adapter
- D. 2" Eyepiece
- E. 2" Barlow or Powermate
- F. 2" Diagonal
- H. 1 1/4" 60° Everbrite Mirror Diagonal
- I. 2" Camera Adapter
- J. T-Ring
- K. D/SLR
- L. 0.8x Reducer/Flattener
- M. 3.5" Extension Tube
- N. 2" Extension Tube
- O. 2" Powermate with T-Ring Adapter
- P. 1 1/4" Powermate with T-Ring Adapter
- Q. Digital Camera
- R. Digital Camera Adapter

