

INSTRUCTION MANUAL

EQ6-R Mount

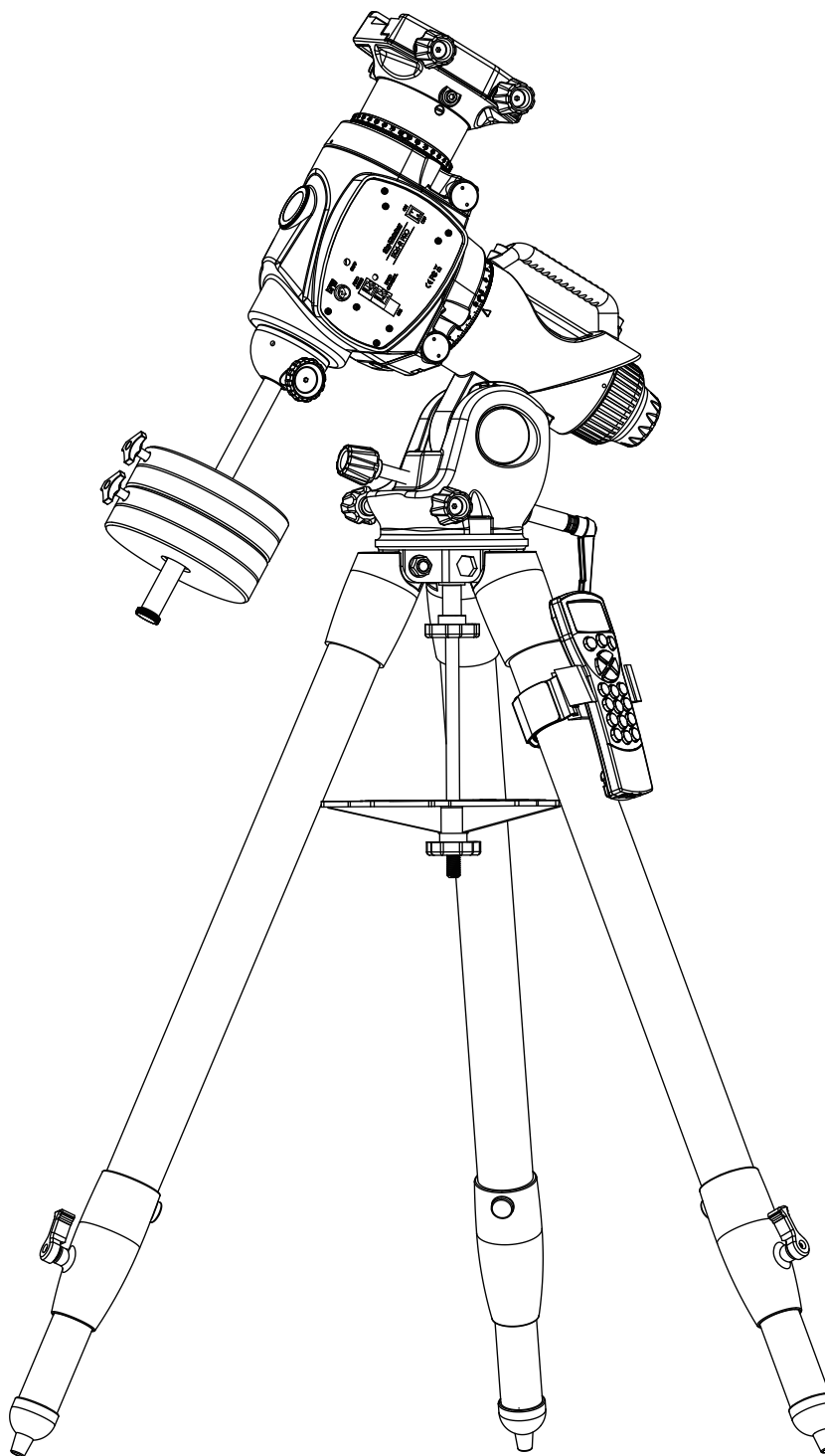

EQ6-R-S-201218V1-EN

CONTENT

PART I : SETTING UP THE EQ6-R MOUNT

1.1 Setting Up the Tripod	3
1.2 Putting On the EQ6-R Mount	3
1.3 Attaching the Accessory Tray and the Hand Controller Holder	4
1.4 Installing the Counterweights	5
1.5 Installing the Telescope	5
1.6 Balancing the Mount	6

PART II : USING THE EQ6-R MOUNT

2.1 Manually Rotating the Mount	7
2.2 Using the Dials	7
2.3 Adjusting the R.A. Axis's Elevation and Azimuth	8

PART III : POLAR ALIGNMENT

3.1 Preparation	9
3.2 Alignment	10
3.3 The Orientation of the Polaris	11
3.4 Align the Polar Scope	11

PART IV : ELECTRONIC CONTROL INTERFACE

4.1 Control Panel	13
4.2 Panel Interface Components	13
4.3 Pinout of the Interfaces	14
4.4 Power Supply Requirements	14

PART V : OTHER EQ6-R MOUNT FEATURES

5.1 Permanent Periodic Error Correction	15
5.2 Batch Exposures Function	15
5.3 SynScan Telescope Control System	15

APPENDIX I : SPECIFICATIONS

Dimensions	16
Specifications	16

Note: The ① ② ③ signs on the diagrams are *not* related to the Chapter Steps 1. 2. 3.

PART I : SETTING UP THE EQ6-R MOUNT

1.1 Setting Up the Tripod

1. Fully expand the tripod legs on level ground.
2. Locate the locking clamps on the legs and turn counter-clockwise to unlock them to extend the tripod legs.
3. Extend the legs to desired height, make sure the tripod top is level and then lock the clamps.

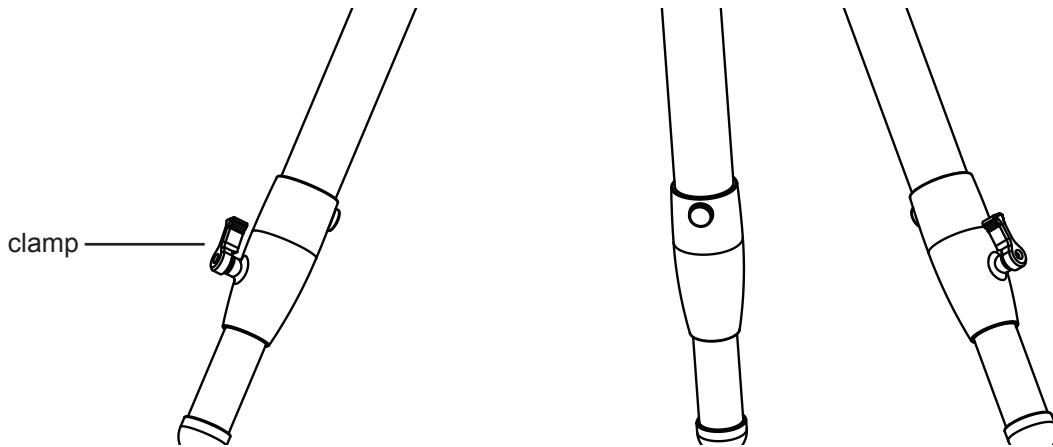

Fig. 1.1

1.2 Putting On the EQ6-R Mount

1. Loosen the two azimuth adjustment knobs on the EQ6-R mount until there is sufficient space between the two knob screws. (Fig. 1.2a)

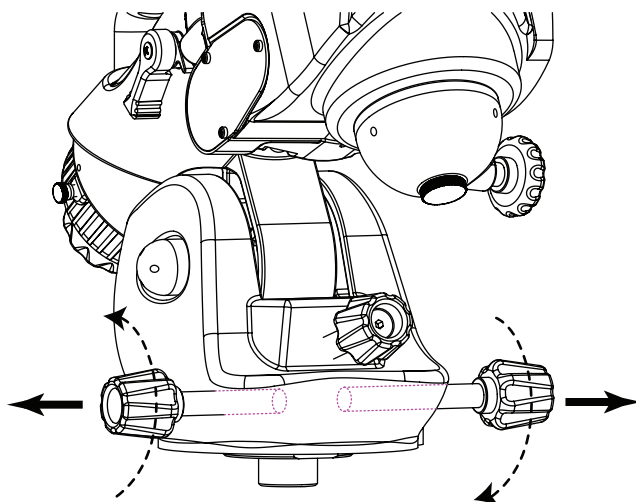

Fig. 1.2a

* Azimuth Adjustment Knobs

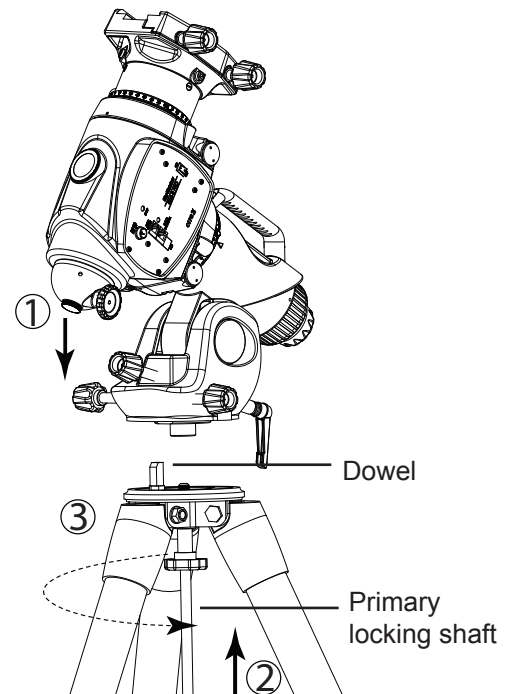

Fig. 1.2b

2. Align the metal dowel on the tripod top with the gap between the two azimuth adjustment knobs; then put the mount on the tripod top. (Fig. 1.2b)
3. Once the mount is seated, slightly tighten the two azimuth adjustment knobs.
4. While supporting the mount with one hand, gently push the primary locking shaft up against the underside of the mount and turn the shaft counter-clockwise to secure the mount to the tripod top. Tighten the shaft with the knurled knob on the primary locking shaft. (Fig. 1.2b)

1.3 Attaching the Accessory Tray and the Hand Controller Holder

1. Slide the accessory tray along the primary locking shaft until its three tips push against the tripod legs, and then secure the tray with the washer and the locking knob. (Fig. 1.3a)
2. By referring to the bubble leveler on the mount, level the mount by adjusting the length of the tripod legs. (Fig. 1.3b)
3. Tie the hand controller holder on one of the tripod leg at a position between the accessory tray and the tripod head. (Fig. 1.3b)

Warning: The accessory tray will ensure the tripod legs remain firmly expanded, which will prevent the tripod from accidentally toppling over. When using the EQ6-R mount, an accessory tray should always be used to ensure stability.

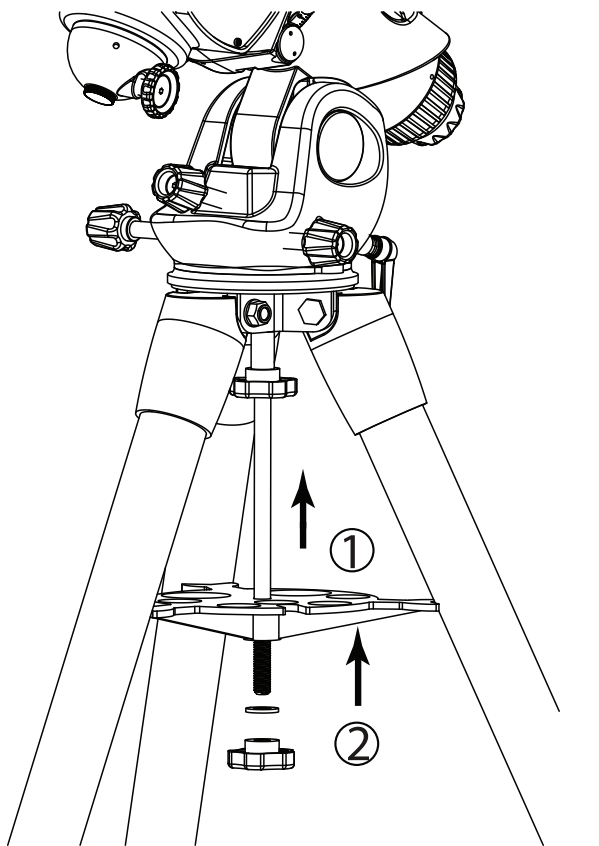

Fig. 1.3a

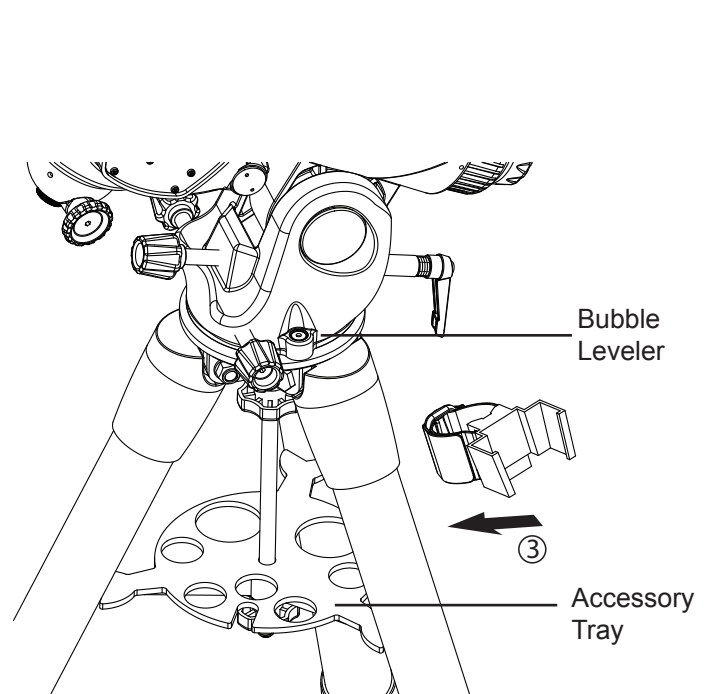

Fig. 1.3b

1.4 Installing the Counterweights

1. Loosen the knob for locking the counterweight rod and gently pull out the counterweight rod. Re-tighten the knob to secure the counterweight rod in place. (Fig. 1.4a)
2. Loosen the R.A. clutch with the lever, and rotate the R.A. Axis until the counterweight rod is pointing towards the ground. (Fig. 1.4b)
3. Remove the threaded cap from the end of the counterweight rod.
4. The EQ6-R mount comes with a 290mm counterweight rod extension, which can be installed at this point if necessary. Ensure the extension is tightly secured before installing counterweights. (Fig. 1.4c)
5. Loosen the counterweight's thumb screw and slide the counterweight onto the counterweight rod. Re-tighten the thumb screw to secure the counterweight on the rod.
6. Replace the cap to the end of the counterweight rod.

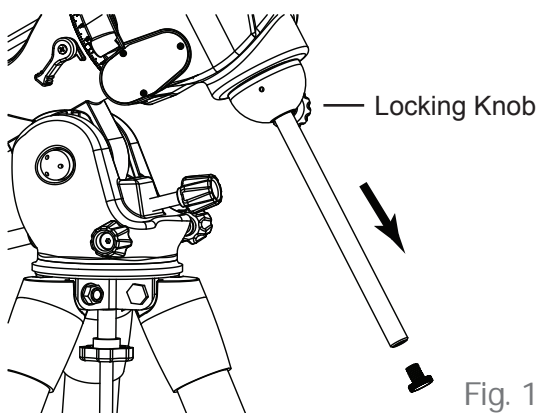

Fig. 1.4a

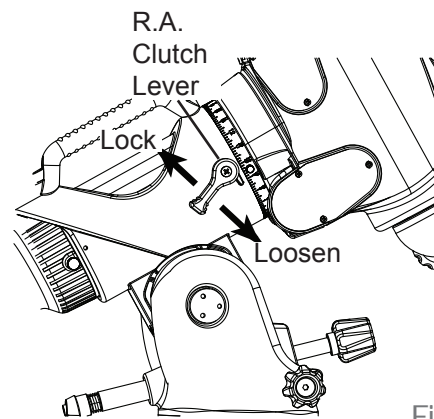

Fig. 1.4b

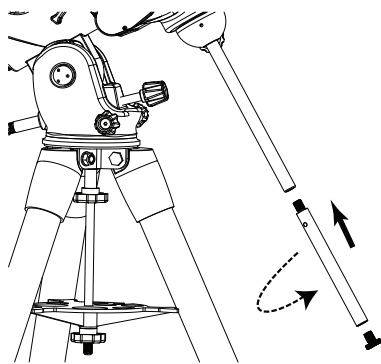

Fig. 1.4c

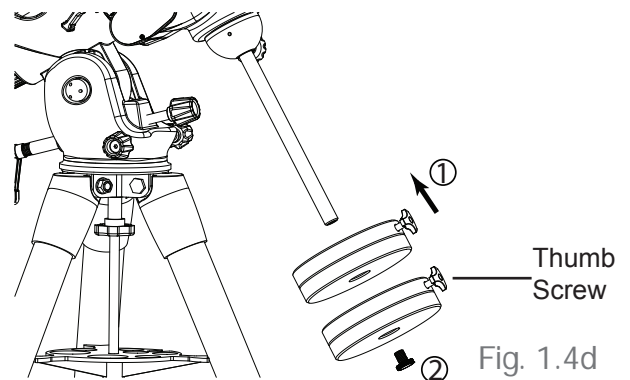

Fig. 1.4d

1.5 Installing the Telescope

1. Before installing a telescope, ensure:
 - The counterweight rod is pointing towards the ground.
 - All counterweights have been moved to the end of the counterweight rod.
 - The R.A. Axis is secured by tightening the R.A. Clutch.

2. Release the Dec. clutch knob and rotate the Dec. axis until the two knobs on the dual-fit saddle are facing upward and the dovetail groove is leveled. Tighten the Dec. clutch again.

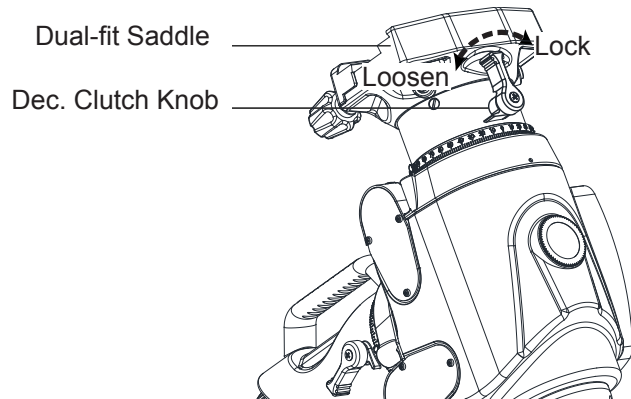

Fig. 1.5

3. Loosen the two knobs on the saddle until the width of one of the dovetail grooves is slightly wider than the width of the dovetail bar on the telescope.
4. While holding the telescope horizontally, seat or slide the dovetail bar of the telescope to the proper groove of the saddle. The lower groove is for a 45mm width dovetail bar and the upper groove is for a 75mm one.
5. Tighten the two knobs to secure the dovetail bar in the groove.

Warning: Keep supporting the telescope until you are sure that it has been firmly attached to the saddle.

1.6 Balancing the Mount

Once the counterweight, telescope, and accessories tray have been installed, the mount should be balanced to reduce stress on the motor drive system, as well as to ensure smooth and accurate operation.

1. Loosen the R.A. Clutch and rotate the R.A. Axis until the counterweight rod is parallel to the ground. Tighten the R.A. Clutch.
2. Loosen the Dec. clutch and rotate the Dec. axis until the telescope is parallel to the ground. Tighten the Dec. clutch.
3. Loosen the thumb screws on the counterweights.
4. Hold the counterweight rod with one hand, release the R.A. Clutch and adjust the counterweights along the rod until the mount is able to remain stationary without support. Tighten the thumb screws on the counterweights again.
5. Rotate the R.A. Axis; the mount should remain relatively balanced along different angles. Once this is confirmed, return the mount to its original position described in Step 1 and tighten the R.A. Clutch again.
6. Hold the telescope with one hand and release the Dec. clutch.
7. Slowly let go of the telescope and check for any rotational movements. If there is a movement, adjust telescope position with relation to the tube rings and saddle. The final position of the telescope should remain stationary without support.

PART II : USING THE EQ6-R MOUNT

2.1 Manually Rotating the Mount

Refer to the following diagrams:

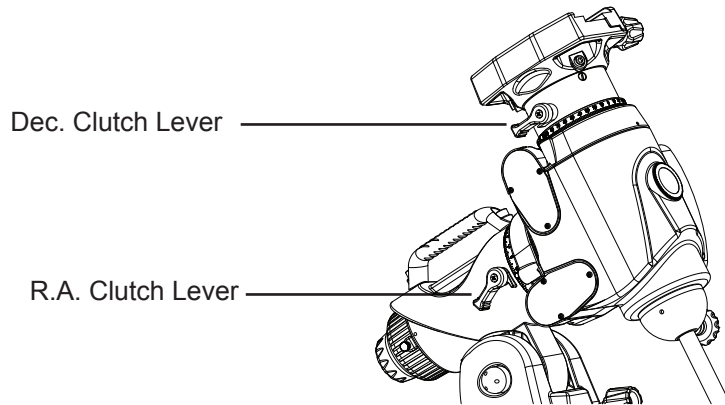

Fig. 2.1

1. Loosen the R.A. clutch lever to manually rotate the R.A. Axis. (Fig. 2.1)
2. Loosen the Dec. clutch lever to manually rotate the Dec. axis. (Fig. 2.1)
3. Both the R.A. clutch and the Dec. clutch should be tightened when driving the mount with the internal motors.

2.2 Using the Dials

As displayed below, the EQ6-R mount features a R.A dial and a Dec. dial.

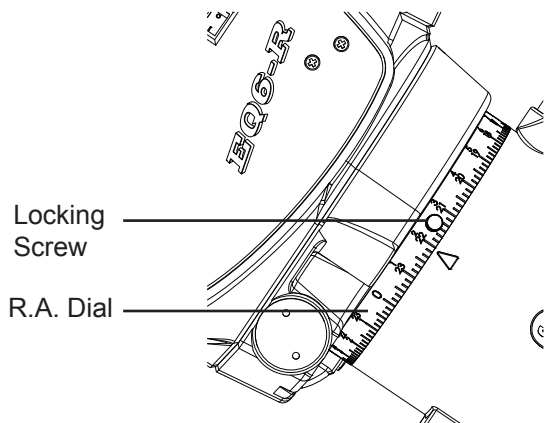

Fig. 2.2a

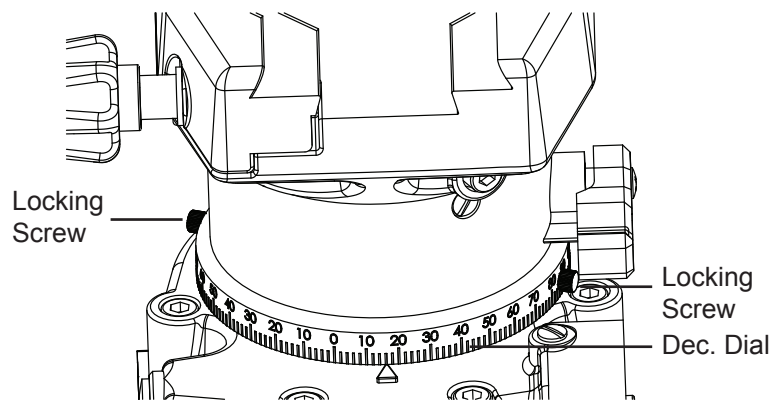

Fig. 2.2b

1. Before using the dials, they need to be calibrated: Point the telescope towards a known coordinate (R.A.-Dec. coordinates). Loosen the two locking screws to turn the dials and let the dials read the known coordinates, then tighten the locking screws again.

2. Once the dials are calibrated, the mount can either be motor-driven or moved manually to specified coordinates by referring to the dial readings.
3. The R.A. dial features two different scales: the lower scale is used to indicate the right ascension when mount is operating in the Southern Hemisphere; the upper scale is used to indicate the right ascension when operating in the Northern Hemisphere.
4. The Dec. dial is divided into four quadrants of 90-degree scales, used to indicate the declination. Users should use the proper segment when calibrating the Dec. dial.

2.3 Adjusting the R.A. Axis's Elevation and Azimuth

1. Use the two azimuth adjustment knobs to rotate the mount horizontally.
2. Use the two elevation adjustment bolts to rotate the R.A. axis vertically.

Note: Push the spring loaded handle towards the bolt to turn the bolt.

Warning: Make sure to loosen one altitude adjustment bolt before tighten the other.

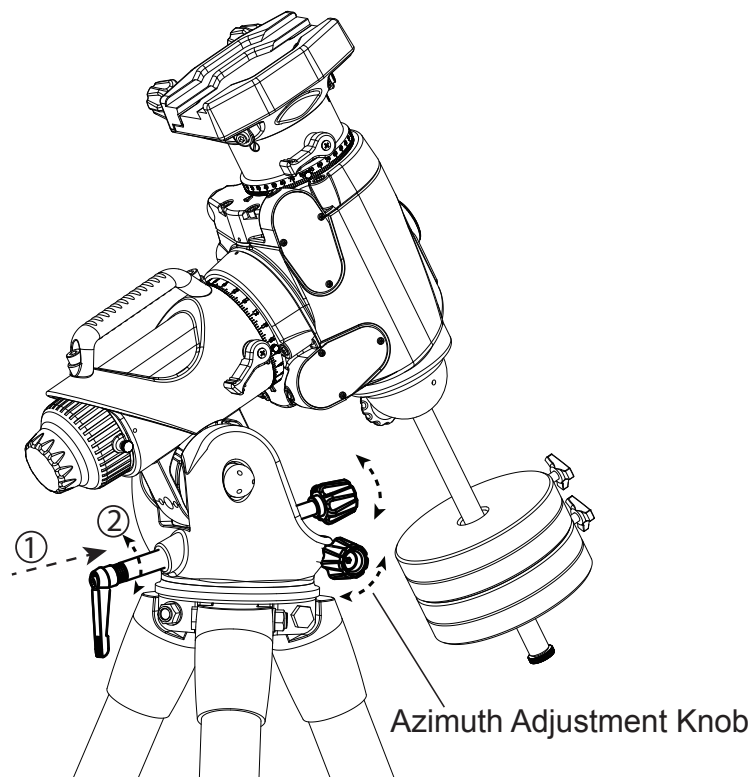

Fig. 2.3

PART III : POLAR ALIGNMENT

3.1 Preparation

1. Setup the EQ6-R mount (*Refer to PART I : SETTING UP THE EQ6-R MOUNT*). It is recommended to load the mount with the telescope and counterweights prior to polar alignment.
2. Point the polar scope to the direction of the North Pole (For Northern Hemisphere observing) or South Pole (For Southern Hemisphere observing). Set the R.A. axis's elevation to the local latitude (*Refer to 2.3 Adjusting the R.A. Axis's Elevation and Azimuth*)
3. Remove the polar scope cap on the mount, loosen the Dec. clutch, and rotate the Dec. axis to allow the hole on the Dec. shaft to fully open for the polar scope and then lock the Dec. clutch again. (Fig. 3.1a & Fig. 3.1b)

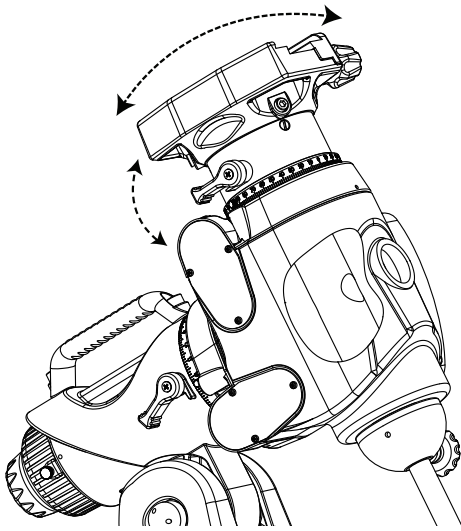

Fig. 3.1a

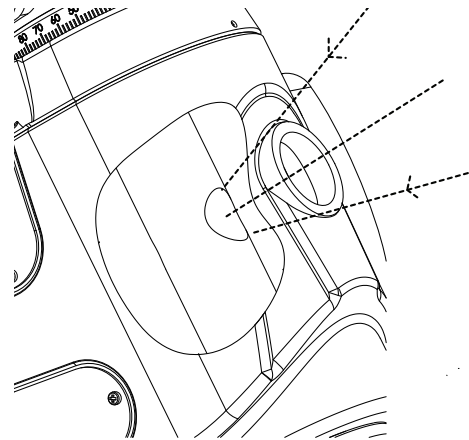

Fig. 3.1b

4. Verify whether the polar scope is aligned with the R.A. Axis. (*Refer to 3.4 Align the Polar Scope*).
5. Turn on the power on the mount to illuminate the polar scope.
6. Find Polaris (For northern hemisphere) or the 4 stars asterism(For southern hemisphere) in the Polar Scope.

3.2 Alignment

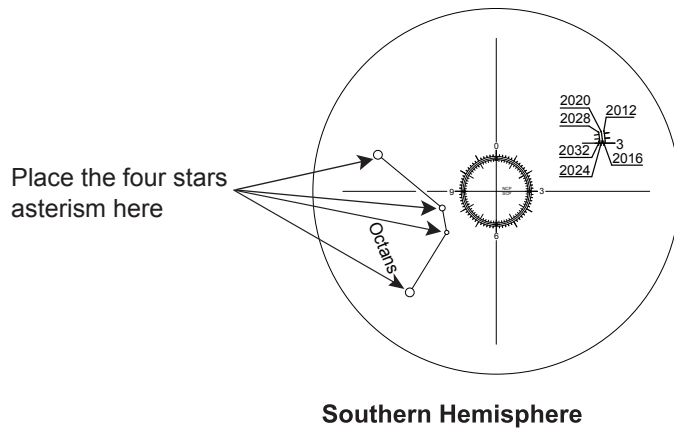

Fig. 3.2a

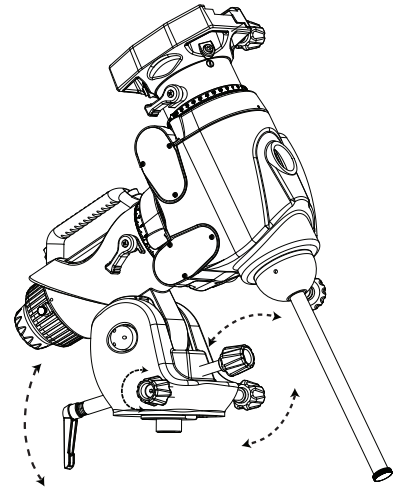

Fig. 3.2b

Once the mount is powered up and the polar scope is illuminated, the pattern in the above figure (Fig. 3.2a) should be visible in the field of view (FOV) of the polar scope. If the image appears blurred, rotate the knurled ring of the polar scope's eyepiece to focus.

- 1. For observing in Northern Hemisphere:** Find the Polaris (The brightest star near the North Celestial Pole) in the polar scope; then use the two elevation adjustment bolts and the two azimuth adjustment knobs to move the Polaris to the proper position in the FOV of the polar scope. (*Refer to the upcoming section "The Orientation of Polaris in Polar Scope"*).
- 2. For observing in Southern Hemisphere:** In the FOV of the polar scope, locate the 4 dim stars (Around Magnitude 5 to 6) which form the pattern like the "Octans" drawing in the polar scope (refer to Fig. 3.2a). Loosen the R.A. clutch and rotate the R.A. axis to align the orientation of the "Octans" drawing to the 4 stars. Then use the elevation adjustment bolts and the azimuth adjustment knobs to move the 4 stars to the 4 small circles of the "Octans" drawing.

3.3 The Orientation of the Polaris:

As the Polaris is not located exactly at the North Celestial Pole, we can see it orbits the North Celestial Pole in a polar scope. The large circle seen in the center of the pattern in Fig. 3.2a is a representation of the Polaris' orbit around the North Celestial Pole. When performing the polar alignment process, it is necessary to determine the orientation of the Polaris on the circle. We can use the following 2 methods to get the orientation:

1. Locate both the Polaris and the Kochab in the sky near the North Celestial Pole. The direction from the Polaris to the Kochab can be used as proximity of the orientation of the Polaris in the polar scope. Put the Polaris to the same direction on the large central circle in the polar scope to finish the polar alignment. This method is somewhat less accurate.
2. At the end of the initialization of the SynScan hand control, after entering the proper local longitude, latitude, date, time, and daylight-saving time, the SynScan hand controller will display the message: "Polaris Position in P.Scope=HH:MM". Imagine the larger circle in Fig. 3.2a as a clock's face with 12:00 at the top, with the current time pointing to the "HH:MM". The orientation of the hour hand of the clock represents the orientation of the Polaris in the polar scope. Put the Polaris to the same orientation on the large circle to finish the polar alignment.

Polaris position also changes as time passes. The reticle in Fig. 3.2a displays 3 circles to represent Polaris's orbit in year 2012, 2020 and 2028. It also gives sub-dials at 0, 3, 6, and 9 o'clock position for year 2016, 2024 and 2032. An engraving labeled with the above years is also displayed on the right of the FOV for memo purpose. When doing polar alignment in Northern hemisphere, the user should put Polaris on the correct circle corresponding to the present year for better alignment precision.

3.4 Align the Polar Scope

Before using the polar scope for polar alignment, the polar scope itself must be calibrated to ensure the pattern in the polar scope is aligned to the mount's R.A. axis. The following steps will outline how to calibrate the polar scope:

1. Choose a fixed object (the Polaris at night, or a faraway object in daytime); put the reticle in the FOV of the polar scope on the object by adjusting the two azimuth adjustment knobs and the two elevation adjustment bolts.
2. Rotate the mount in R.A. axis for half a turn. The R.A. dial can be used for an accurate rotation. Tighten the R.A. clutch after the rotation.

3. If the object remains at the center of the reticle in the polar scope after the rotation, then it means the polar scope has been aligned to the R.A. axis and no calibration is needed.
4. If the target deviated from the reticle, then use a 1.5mm Allen wrench to adjust the three small Allen screws on the polar scope (Fig. 3.4a) to eliminate the deviation to half. (Fig. 3.4b)
5. Repeat steps 1 to 4 a few times until the object keeps at the center of the reticle when rotating the mount in R.A. axis.

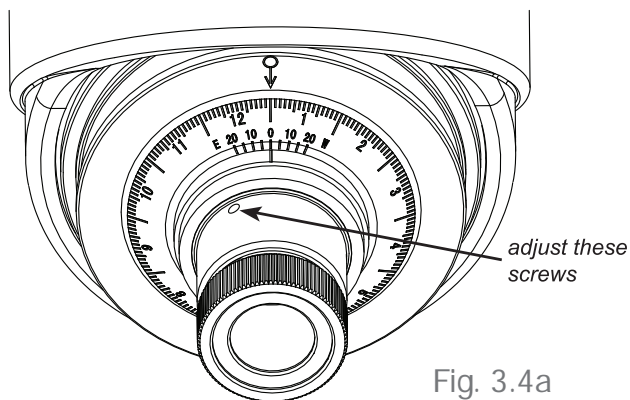

Fig. 3.4a

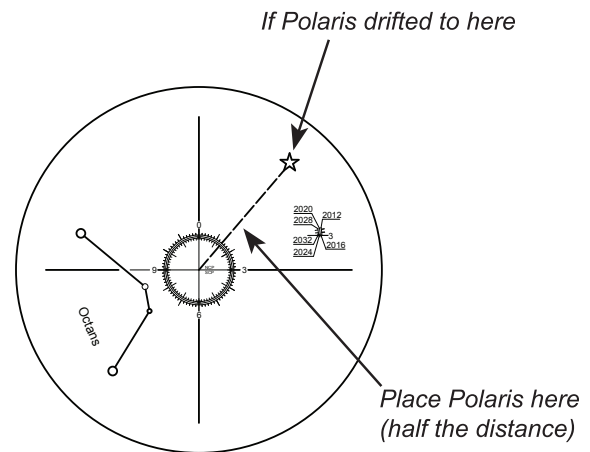

Fig. 3.4b

Note:

- When adjusting the Allen screws, loosen one screw only $\frac{1}{4}$ of a turn, and then tighten the other two.
- Do not over tighten the Allen screws; it might damage the pattern plate in the polar scope.
- Do not loosen one screw completely or loosen more than one screw at a time; otherwise, the pattern plate in the polar scope will be disengaged and further adjustment is impossible.
- If the pattern plate does disengage, remove the polar scope's eyepiece by turning the knurled ring counterclockwise and then engage the pattern plate again.

PART IV : ELECTRONIC CONTROL INTERFACE

4.1 Control Panel

The control panel of the EQ6-R is shown below:

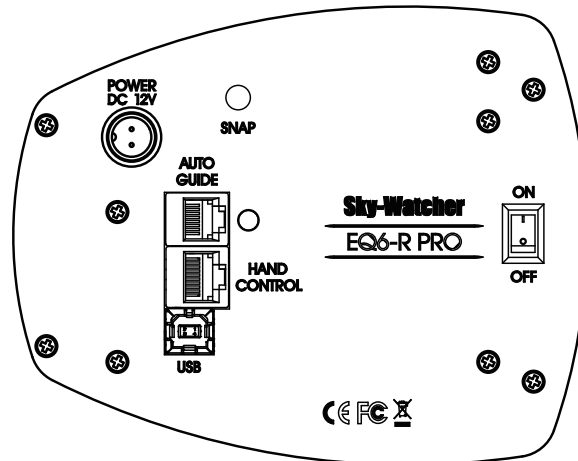
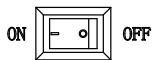

Fig. 4.1

4.2 Panel Interface Components:



POWER: This is an outlet from which the mount and the hand control get power supply. To connect to a power supply, align the index on both the plug of the cord and the outlet on the panel, and then insert the plug to the outlet. Tighten the knurled cap on the plug to secure the plug on the panel.



POWER Switch: Turns on and off the power to the mount and hand controller.

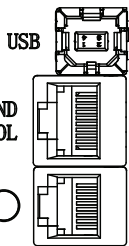

USB: It provides a USB-to-Serial connection for controlling the mount.

HAND CONTROL: This RJ-45 8-pins outlet is for connecting a SynScan hand controller or a SynScan Wi-Fi dongle.

AUTO GUIDE: This RJ-12 6-pins outlet is for connecting an autoguider. It is compatible with any autoguider with a ST-4 type interface.

LED: The LED beside the Autoguider port serves as a power-on/status indicator.

1. Steady on: Power voltage is normal.
2. Slow flashing: Power voltage is low; continuing to operate the mount may damage the battery (if a 12V lead-acid battery is in use).
3. Fast flashing: Power voltage is extremely low; continuing to operate the mount may damage the battery and the motor controller in the mount.
4. Intermittent one flash: The PPEC training routine has been triggered, but the controller in the mount has not received the worm index signal and the correction-recoding has not started yet.

4. Intermittent two flashes: The PPEC training routine has been started and the controller in the mount has received the worm index signal and started to record the PE correction. When the intermittent two flashes stops, it means the PPEC training has finished.
5. Intermittent, three flashes: Sidereal tracking with PEC is now enabled.

SNAP

SNAP: This is a stereo outlet for connecting to a camera's remote control port.

4.3 Pinout of the Interfaces:

Fig. 4.3

Note:

- The SNAP port provides two trigger signals to the stereo plug. Some cameras need both “Shutter” and “Focus” signals.
- For a camera which only needs a shutter-release signal, either trigger signals will work. For a camera which requires a “Focus” signal ahead of the shutter-release signal, both signals should be connected properly.
- The camera control cable shipped with the EQ6-R mount is for a Canon EOS series DSLR camera. Cable for other cameras is optional and can be ordered separately.

4.4 Power Supply Requirements

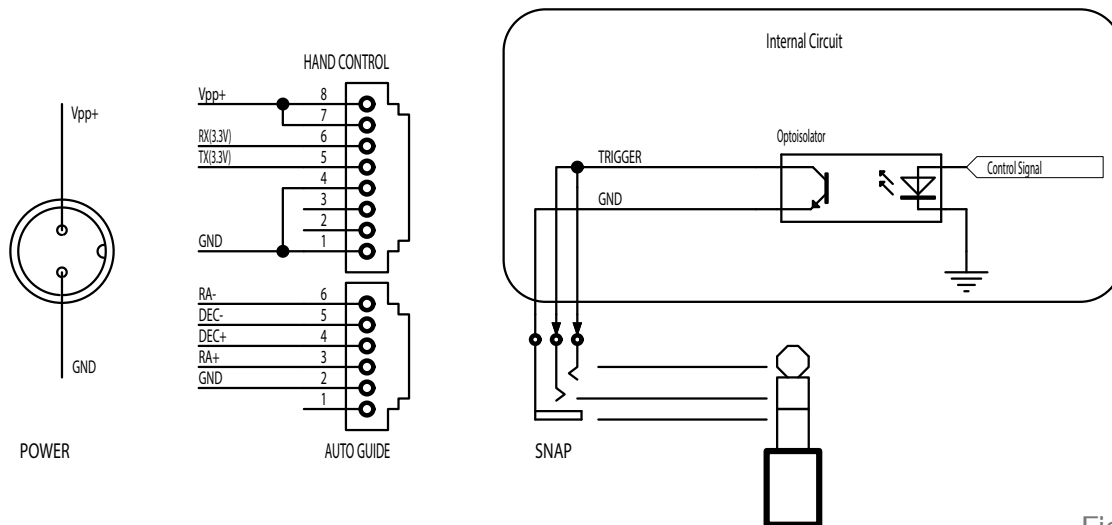
- Output Voltage: DC 11V (minimum) to DC 16V (maximum). Voltage not in this range might cause permanent damage to the motor controller or the hand controller.
- Output Current: 4A for power supply with 11V output voltage, 2.5A for power supply with 16V output voltage.
- Do not use an un-regulated AC-to-DC adapter. Contact a Skywatcher product retailer for a recommended “AC-DC Adapter for SynScan Goto”, SKU#79024.
- If the power voltage is too low, the motor controller will stop the motors automatically.

PART V : OTHER EQ6-R MOUNT FEATURES

5.1 Permanent Periodic Error Correction

The EQ6-R mount is equipped with an index on its R.A. worm thus the motor controller can keep tracking the current position of the worm. After a proper PEC training routine, in which the training data is stored in the motor controller permanently, a user can start the periodic error correction (PEC) at any time to improve the tracking performance for short focal length astrophotography. A training process is not required in the next observing session (assuming that the polar alignment is always accurate), thus this is a Permanent Period Error Correction (PPEC). A user can train the mount with manual guiding or auto-guiding. For detailed instructions, please refer to the relevant section in the SynScan hand controller instruction manual.

5.2 Batch Exposures Function

The EQ6-R mount is equipped with a SNAP port which can control the shutter releasing of a camera. Working with the SynScan hand control's "Camera Control" function, a user can take batch exposures when doing astrophotography. Up to 8 groups of "Exposure-time & Frames" combinations can be set on the SynScan hand controller. For detailed information, refer to the SynScan hand control's instruction manual.

5.3 SynScan Telescope Control System

The EQ6-R mount is equipped with an on board USB port, a SynScan WiFi dongle can also be attached. Users can control the mount with the following options:

- SynScan hand control.
- SynScan Pro app for iOS: over Wi-Fi connection.
- SynScan Pro app for Android: over Wi-Fi or USB connection
- SynScan Pro for Windows: over W-Fi or USB connection
- SynScan Pro for Mac or Linux (under development): over Wi-Fi or USB connection
- SynScanPTZ(for photography): over Wi-Fi

APPENDIX I : SPECIFICATIONS

Dimensions:

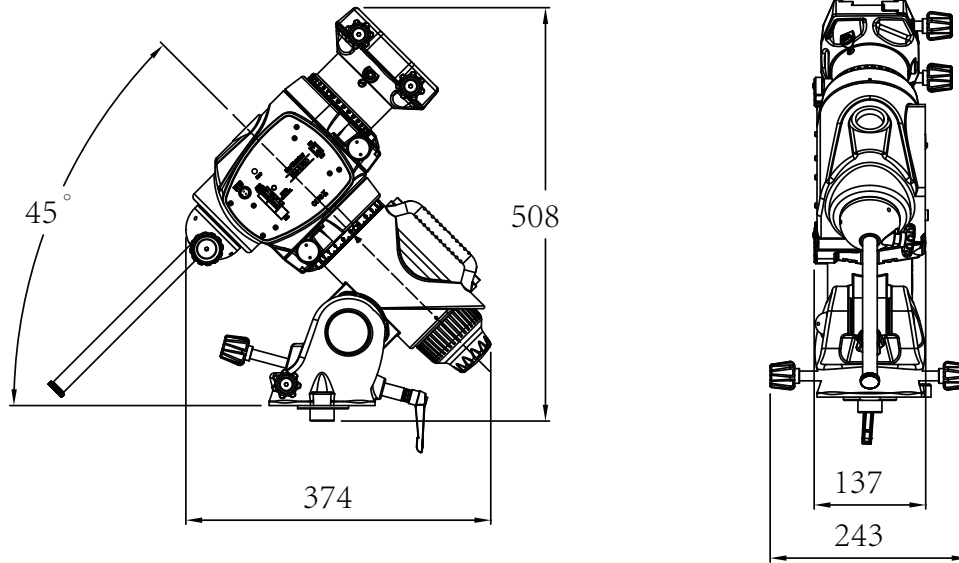

Specifications:

Product Name	EQ6-R Mount
Mount Type	German Equatorial
Payload (Counterweights excluded)	20kg (for Astrophotography)
Latitude Adjustment Range	5° to 65°
Azimuth Adjustment Range	About ±9 °
Weight(Tripod excluded)	17.3 kg
Counterweight	2 x 5kg/ea
Tripod	2-inch stainless steel, 7.5kg
Counterweight Rod	18mm Diameter, Length 240mm + 180mm
Power Requirement	DC11~16V 4A
Motor	1.8 ° Hybrid Stepper Motor
Transmission	180:1 Worm Drive + 48:12 Timing Belt Drive + 64 Micro-step/1.8° Stepper Motor Drive
Gear Ratio	720
Resolution	9216000 Counts/Rev., approx. 0.14 arc-second
Maximum Slewing Speed	4.2 degrees/second
Tracking Rate	Sidereal rate, solar rate, lunar rate
Tracking Mode	Equatorial mode
Auto-guiding Speed	0.125X, 0.25X, 0.5X, 0.75X, 1X
PEC	100 Segments Permanent PEC
Controller	SynScan hand control, iOS/Android Device, PC/Mac
Database	42000+ Objects
Celestial Object Catalog	Messier, NGC, IC, SAO, Caldwell, Double Star, Variable Star, Named Star, Planets
Pointing Accuracy	Up to 5 arc-minutes (RMS)

Note: Specifications are subject to change without notice.

EQ6-R Mount



NEVER USE YOUR TELESCOPE TO LOOK DIRECTLY AT THE SUN. PERMANENT EYE DAMAGE WILL RESULT. USE A PROPER SOLAR FILTER FIRMLY MOUNTED ON THE FRONT OF THE TELESCOPE FOR VIEWING THE SUN. WHEN OBSERVING THE SUN, PLACE A DUST CAP OVER YOUR FINDERSCOPE OR REMOVE IT TO PROTECT YOU FROM ACCIDENTAL EXPOSURE. NEVER USE AN EYEPIECE-TYPE SOLAR FILTER AND NEVER USE YOUR TELESCOPE TO PROJECT SUNLIGHT ONTO ANOTHER SURFACE, THE INTERNAL HEAT BUILD-UP WILL DAMAGE THE TELESCOPE OPTICAL ELEMENTS.